

Makita

HEDGE TRIMMER

EH 450

EH 620

INSTRUCTION MANUAL

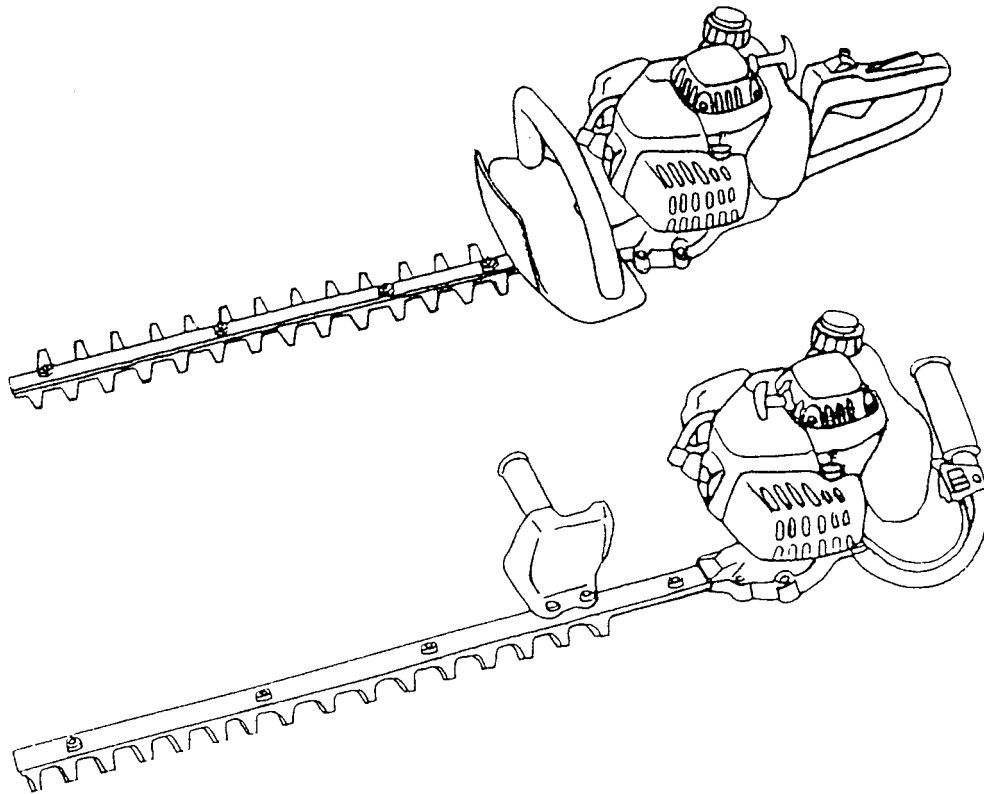

WARNING:

To reduce the RISK of injury, user must read and understand the instruction manual before using the Hedge Trimmer.

Manufacturer reserves the right to change specifications without notice.

Specifications may differ from country to country.

Do only hand over the Hedge Trimmer together with this manual.

Thank you very much for selecting the MAKITA Hedge Trimmer. We are pleased to be able to offer you the MAKITA Hedge Trimmer which is the result of a long development program and many ears of knowledge and experience.

The Hedge Trimmer models EH450/620 combines the advantages of state-of-the-art technology with ergonomic design, they are light weight, handy, compact and represent professional equipment for a great variety of applications.

For your safety and best tool performance, be sure to read, understand and follow all the safety and operating procedures listed in the instruction manual before operation.



Table of Contents

Page

Symbols 2
 Safety instructions 3-6
 Specification 6
 Name of major parts 7
 Fuels/Refuelling 8-9
 Precautions before starting 9-10
 Starting the machine 10
 Stopping the machine 10
 Operation of the machine 11
 Maintenance instructions 12-14
 Storage 15
 Maintenance schedule 15
 Fault location 15

SYMBOLS

It is very important to understand the following symbols when reading this instructions manual.

	WARNING/DANGER		Fuel and Oil Mixture
	Read, Understand and Follow Instruction Manual		Engine-manual Start
	Forbidden		Emergency Stop
	No Smoking		First Aid
	No Open Flame		Recycling
	Protective Gloves must be Worn		ON/START
	Keep the Area of Operation Clear of All Persons and Pets		OFF/STOP
	Wear Eye and Ear Protection		

SAFETY INSTRUCTIONS

General Instructions

- This machine can cause serious injuries if used incorrectly. To ensure correct operation, users have to read this instruction manual to make themselves familiar with the handling of the Hedge Trimmer. Users insufficiently informed will risk danger to themselves as well as others due to improper handling. (1)
- It is recommended only to loan the Hedge Trimmer to people who have proven to be experienced with Hedge Trimmers. Always hand over the instruction manual.
- First-time users should ask the dealer for basic instructions to familiarise themselves with the handling of an engine powered Hedge Trimmer.
- Children and young persons aged under 18 years must not be allowed to operate the Hedge Trimmer. Persons over the age of 16 years may however use the device for the purpose of being trained only while under the supervision of a qualified trainer .
- Use the Hedge Trimmer with the utmost care and attention.
- Operate the Hedge Trimmer only if you are in good physical condition. Perform all work calmly and carefully. The user has to accept liability for others.
- Never use the Hedge Trimmer after consumption of alcohol or drugs, or if feeling tired or ill. (2)

Intended use of the machine

- The Hedge Trimmer is only designed for the purpose of trimming bushes and hedges, and must not be used for any other purpose. Do Not abuse the Trimmer.

Personal protective equipment

- The blade cover must be fitted when transporting the machine.
- The clothing worn should be functional and appropriate, i.e. it should be tight-fitting but not cause hindrance. Do not wear jewelry or loose clothing which could become entangled with bushes or shrubs, or the machine.
- In order to avoid eye, hand or foot injuries as well as to protect your hearing, the following protective equipment and protective clothing must be used during operation of the Hedge Trimmer.
- Always wear safety goggles for eye protection that meets ANSI Z87.1.
- Wear adequate noise protection equipment to avoid hearing impairment, ear muffs, ear plugs, etc. (3)
- Wear proper clothing to protect legs and other exposed parts of your body. (4)
- Gloves made of thick leather are part of the prescribed equipment and must always be worn during operation of the Hedge Trimmer. (4)
- When using the Hedge Trimmer, always wear sturdy shoes with a non-slip sole. This protects against injuries and ensures a good footing. (4)

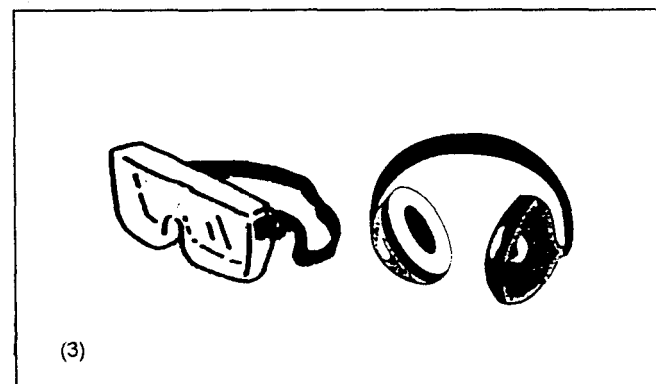
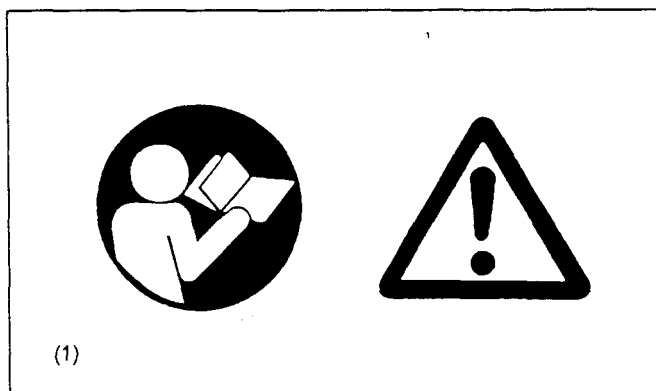

Starting up the Hedge Trimmer

- Please make sure that there are children or other people within a working range of 50 feet or 15 meters (5), also pay attention to any animals in the working vicinity
- **Before operating, always check that the Hedge Trimmer is safe for operation:**
Check the security of the throttle lever. The throttle lever should be checked for smooth and easy action. Check for proper functioning of the throttle lever lock. Check for clean and dry handles and test the function of the STOP switch. Keep handles free of oil and fuel.

Start the Hedge Trimmer only in accordance with the instructions.

Do not use any other methods for starting the engine (6)!

- Use the Hedge Trimmer only for applications specified.
- Start the Hedge Trimmer engine only after the entire assembly is done. Operation of the Hedge Trimmer is permitted only after all the appropriate accessories are attached!
- Before starting, make sure that the cutter blade will not contact any objects such as branches, stones, etc.
- The engine is to be stopped immediately if there are any engine problems.
- When working with the Hedge Trimmer, keep both hands on handles always wrap your fingers tightly around the handle, keeping the control handle cradled between your thumb and forefinger. Keep your hand in this position to have your machine under control at all times. Make sure your control handle is in good condition and free of moisture, pitch, oil or grease.

Always ensure a safe, well-balanced footing

- Only use outdoors.
- Operate the Hedge Trimmer in such a manner as to avoid inhalation of the exhaust gases. Never run the engine in enclosed rooms (risk of suffocation and gas poisoning). Carbon monoxide is an odorless gas. Always ensure there is adequate ventilation.
- Stop the engine when resting and when leaving the Hedge Trimmer unattended. Place it in a safe location to prevent danger to others, setting fire to combustible materials or damage to the machine.
- Never lay down the hot Hedge Trimmer onto dry grass or onto any combustible materials.
- Never operate the engine with a faulty exhaust muffler.
- Stop the engine during transport (7).
- Secure the tool properly before transporting in vehicle to avoid fuel leakage.
- When transporting the Hedge Trimmer ensure that the fuel tank is completely empty to avoid fuel leakage.

Refuelling

- To reduce the risk of fire and burn injury; handle fuel with care. It is highly flammable.
- Stop the engine before refuelling (7), keep well away from open flame (8) and do not smoke.
- Do not attempt to refuel a hot or a running engine.
- Avoid skin contact with petroleum products. Do not inhale fuel vapor. Always wear protective gloves during refuelling. Change and clean protective clothing at regular intervals.
- Take care not to spill either fuel or oil always wipe unit dry before starting engine. Allow wet cloths to dry before disposing in proper, covered container to prevent spontaneous combustion.
- Avoid any fuel contact with your clothing. Change your clothing immediately if fuel has been spilled on it (danger hazard).
- Inspect the fuel cap at regular intervals making sure that it stays securely fastened.
- Carefully tighten the locking screw of the fuel tank. Move at least 10 ft (3 meters) away from the refuelling point before starting engine.
- Never refuel in closed rooms. Fuel vapors accumulate at ground level (risk of explosions).
- Only transport and store fuel in approved containers. Make sure stored fuel is not accessible to children.
- When mixing gasoline with two-cycle engine oil, use only gasoline which contains no ethanol or methanol (types of alcohol). This will help to prevent damage to fuel lines and other engine parts.
- Make sure the unit is properly assembled and in good operating condition.

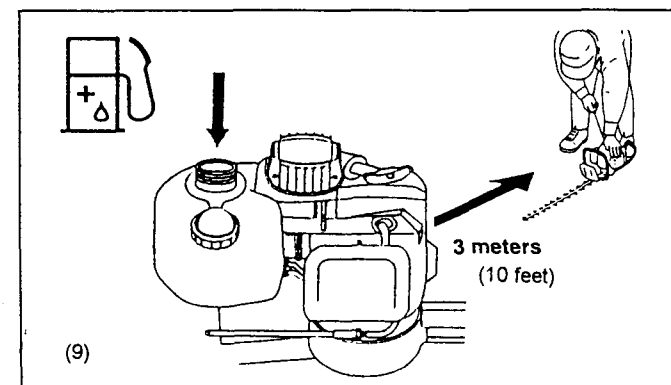
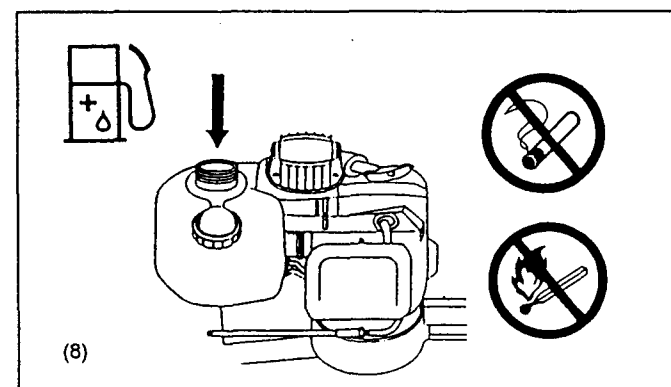
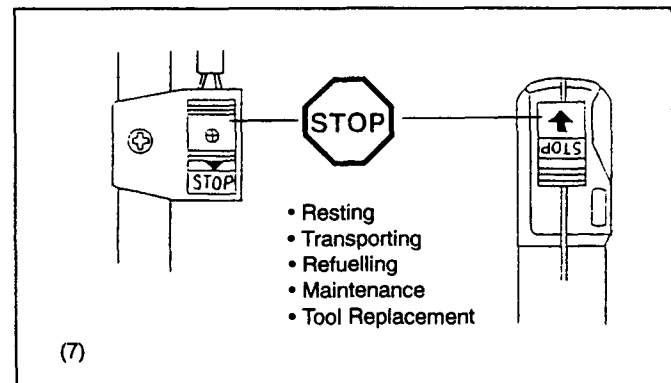
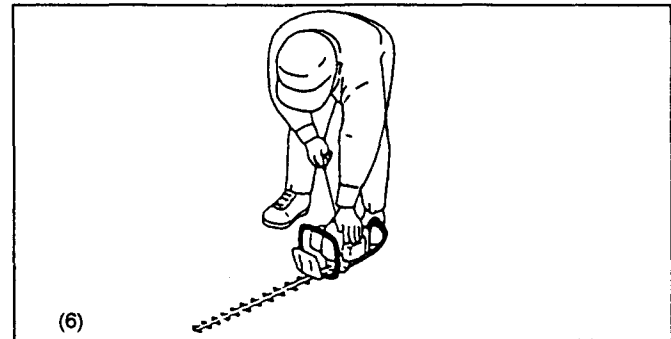
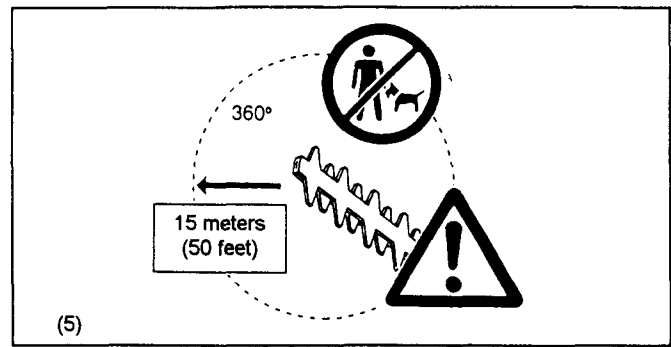

Method of operation

- Use the Hedge Trimmer only in good light and visibility. During cold seasons beware of slippery or wet areas, ice and snow (risk of slipping). Always ensure a safe footing.
- Do not overreach or stand on unstable support. Keep good footing and balance at all times.
- Keep both feet on the ground.
- Never stand on a ladder and the Hedge Trimmer.
- Never climb up into trees to perform cutting operation with the Hedge Trimmer.
- **DANGER-CUT HAZARD-KEEP HANDS AWAY FROM BLADES.**
Don't feed twigs or other material to be cut into the blade with your hands or reach over the moving blade to pick up clippings. Never grasp the exposed cutting blades or cutting edges when picking up or holding the tool. **CAUTION**-Blade may coast after its turned off.
- **KEEP HANDS AND ALL PARTS OF BODY AWAY** from blade. The edges are sharp and can cause injury even when the tool is "OFF"
- **BEFORE TRIMMING**, inspect areas for wires, cords, glass or other foreign objects which could come in contact with the blade.
- Keep both hands on the handles when operating a Hedge Trimmer. Never grasp exposed cutting blades of Hedge Trimmer.
- Make sure engine is stopped and blades have stopped moving before clearing jammed material.
- Be aware of any and all electric lines and electric fences. Check all areas for electrical lines before cutting.
- To reduce the risk of stumbling and loss of control, do not walk backward while operating the machine.



Maintenance instructions

- Always stop the engine before cleaning or servicing the unit or replacing parts.
- **MAINTAIN TOOL WITH CARE.** Keep cutting edges sharp and clean for best and safest performance. Follow instructions for lubricating and proper maintenance.
- Be kind to the environment. Operate the Hedge Trimmer with as little noise and pollution as possible. In particular check the correct adjustment of the carburetor.
- Clean the Hedge Trimmer at regular intervals and check that all screws and nuts are securely tightened.
- Never service or store the Hedge Trimmer in the vicinity of open flames, sparks, etc. (11).
- Always store the Hedge Trimmer in a well-ventilated locked room and with an emptied fuel tank out of reach of children.

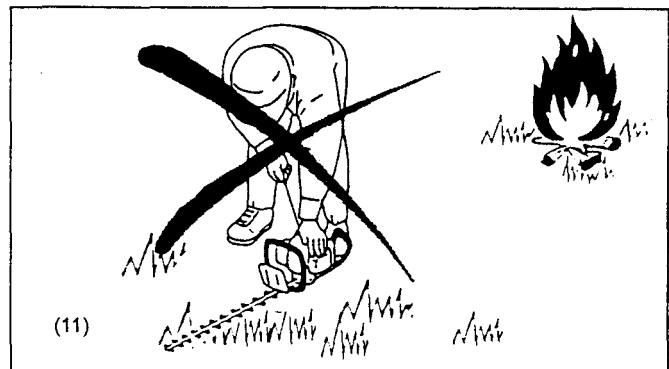

Observe and follow all relevant accident prevention instructions issued by the trade associations safety board and by insurance companies. Do not perform any modifications to the Hedge Trimmer as this will risk your safety.

The performance of maintenance or repair work by the user is limited to those activities as described in this instruction manual. All other work is to be done by Makita authorized or Factory Service Centers.

Use only genuine spare parts and accessories supplied by MAKITA authorized or factory service centers.

Use of non-approved accessories and tools means increased risk of accidents and injuries. MAKITA will not accept any liability for accidents or damage caused by the use of any non-approved accessories.

First aid

In case of an accident make sure that a well-stocked first-aid kit according to DIN 13164, is available in the vicinity of the cutting operations.

Immediately replace any item taken from the first aid kit.

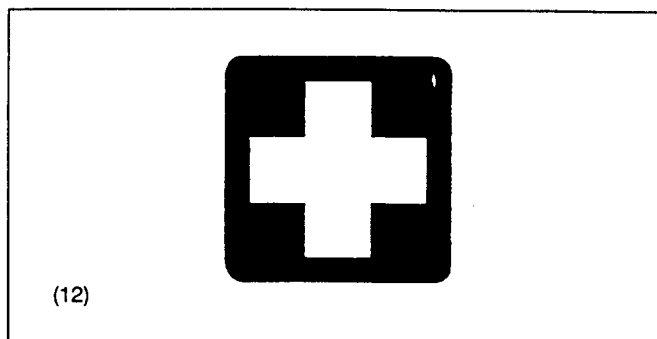

Packaging

The MAKITA Hedge Trimmer is delivered in a protective cardboard box to prevent shipping damage. Cardboard is a basic raw material and is therefore consequently reusable or suitable for recycling (waste paper recycling).



SPECIFICATION

Model		EH450	EH620
Dimensions (L x W x H)	mm	964 x 244 x 218	1,063 x 288 x 218
Mass (with blade cover)	kg	4.4	4.5
Volume (fuel tank)	cm ³	0.4	
Engine displacement	cm ³	20.0	
Cutting length	mm	450	620
Maximum engine performance	kw	0.61	
Maximum blade speed	m/s	1.8	
Idling speed	1/min	3,000	
Clutch engagement speed	1/min	4,000	
Carburetor type	type	WALBRO WYL	
Ignition system	type	Solid ignition system	
Spark plug	type	NGK-BM4A	
Electrode gap	mm	0.6 ~ 0.7	
Mixture ratio (fuel : MAKITA 2-stroke oil)		50 : 1	
Gear ratio		8 : 34	

1) The data takes equally into account idling and racing speed operating modes.

NAME OF MAJOR PARTS

EH450

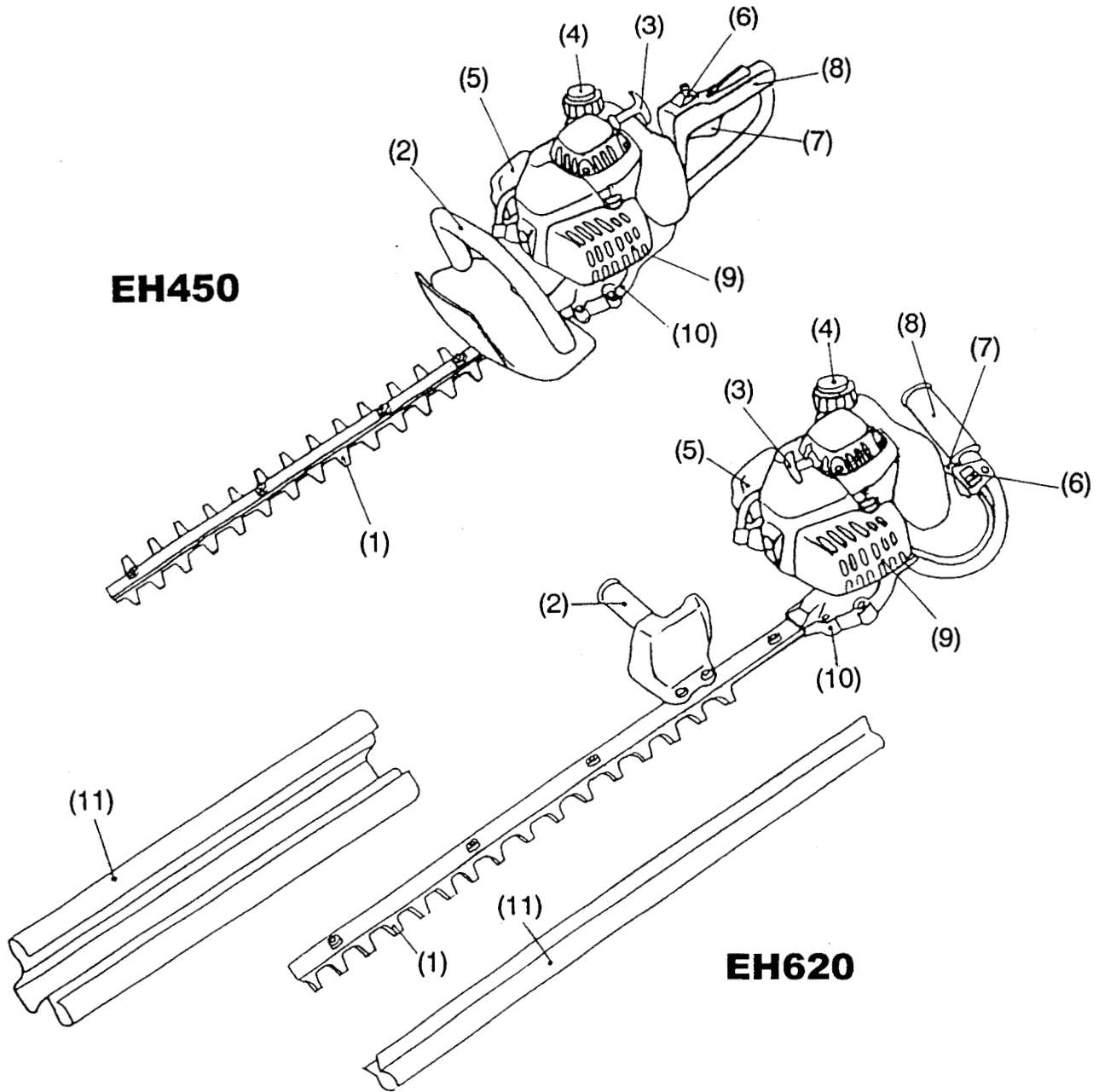

EH620

	NAME OF MAJOR PARTS		NAME OF MAJOR PARTS
1	Blade	7	Throttle lever
2	Front handle	8	Rear handle
3	Recoil starter	9	Muffler
4	Fuel tank cap	10	Gearbox
5	Carburetor	11	Blade cover
6	STOP Switch (ON-OFF)		

FUELS/REFUELLING

Fuel and oil mirture

Inspect the fuel tank and fill with clean, fresh fuel of the proper mixture to assure the longer life of the tool. Use the following mixed gas.

Gasoline : Makita genuine two-stroke engine oil = 50 : 1 or

Gasoline : Other manufacturer's two-stroke engine oil = 25 : 1 recommended

FOR CALIFORNIA REGULATION :

THIS EQUIPMENT IS CERTIFIED TO OPERATE ON GASOLINE + TWO-STROKE ENGINE OIL

WHEN MIXING GASOLINE WITH TWO-STROKE ENGINE OIL, USE ONLY GASOLINE WHICH CONTAINS NO ETHANOL OR METHANOL (TYPES OF ALCOHOL). THIS WILL HELP TO AVOID POSSIBLE DAMAGE TO ENGINE FUEL LINES AND OTHER ENGINE PARTS. DO NOT MIX GASOLINE AND OIL DIRECTLY IN THE FUEL TANK.

IMPORTANT:

Failure to follow proper fuel mix instructions may cause damage to the engine.



- The engine of the hedge Trimmer is a high-efficiency two-stroke engine.

It is run with a mixture of fuel and two-stroke engine oil. The engine is designed for unleaded regular fuel with a min. -octane value of 91 ROZ.

In case no such fuel is available, you can use fuel with a higher octane value. This will not damage the engine, but may cause poor operating behaviour.

A similar situation will arise from the use of leaded fuel.

To obtain optimum engine operation and to protect your health and the environment, only unleaded fuel should be used!

- For lubricating the engine use a two-stroke engine oil (quality grade:TC-3), which is added to the fuel.

The engine has been designed for use with MAKITA two-stroke engine oil and a mixture ratio of 50:1 only to protect the environment. In addition, a long service life and a reliable operation with a minumum emission of exhaust gases is guaranteed. It is absolutely essential to observe a mixture ratio of 50:1 (MAKITA 2-stroke engine oil), otherwise the reliable function of the Hedge Trimmer cannot be guaranteed.

- The correct mixture ratio:

Mix 50 parts gasoline with 1 part MAKITA 2-stroke engine oil (See table on the right)

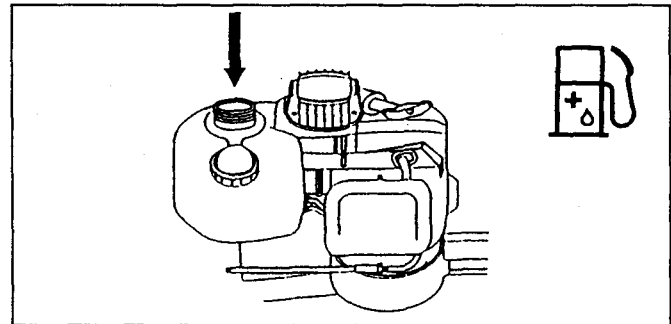
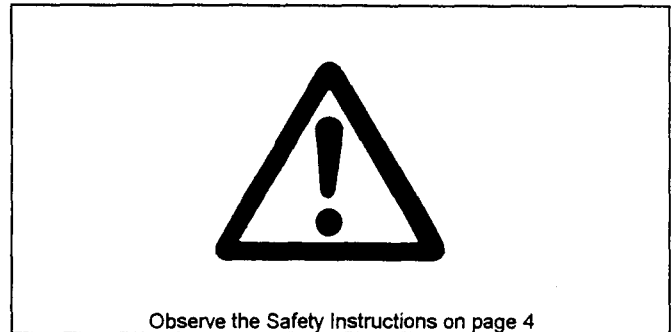

NOTE: For preparing the fuel-oil mixture, first mix the entire oil quantity with half o the fuel required. In an approved can which meets or exceeds all local code standards, then add the remaining fuel.

Thoroughly shake the mixture before filling it into the Hedge Trimmer's tank.

It is not wise to add more engine oil than specified to ensure safe operation. It will only result in a higher production of combustion residues which will pollute the environment and clog the exhaust channel in the cylinder as well as the muffler. In addition, the fuel consumption will rise and the performance will decrease.

Gasoline	50:1
1 GAL	2.6 OZ
2 GAL	6.4 OZ

Handling petroleum products

Utmost care is required when handling fuel. Fuel may contain substances similar to solvents. Refuel either in a well ventilated area or outdoors. Do not inhale fuel vapors, avoid any contact of fuel or oil with your skin.

Mineral oil, fuel, etc., product degrease your skin. If skin comes in contact with these substances repeatedly or for an extended period of time, various skin diseases may result. In addition, allergic reactions are known to occur. Eyes can be irritated by contact with oil, fuel etc. If oil, fuel, etc., comes into your eyes, immediately wash them with clear water. If your eyes are still irritated, see a doctor immediately!

Refuelling

Always stop the engine and allow it to cool before refuelling.

- Thoroughly clean the around the fuel filler cap to prevent dirt from getting into the fuel tank.
- Unscrew the fuel filler cap and fill the tank with fuel.
- Tightly screw on the fuel filler cap.
- Clean the fuel filler cap and tank after refuelling!
Wipe up any fuel

Storage of fuel

- Fuel cannot be stored for an unlimited period of time.
- Purchase only the quantity required for a 4 week operation period.
- Use approved fuel storage containers only.

WARNING!

Gasoline is an extremely flammable fuel. Use extreme caution when handling gasoline or fuel mix. Do not smoke or bring any fire or flame near the fuel.

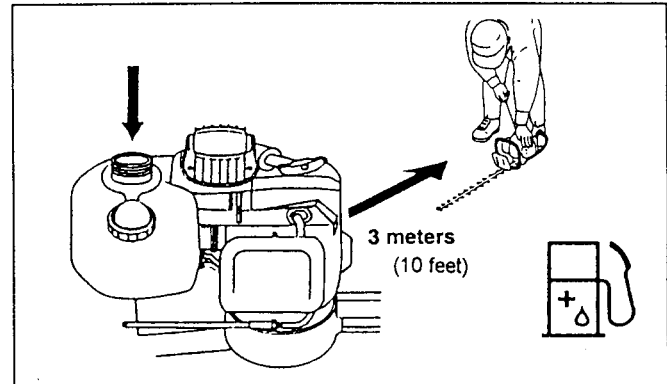
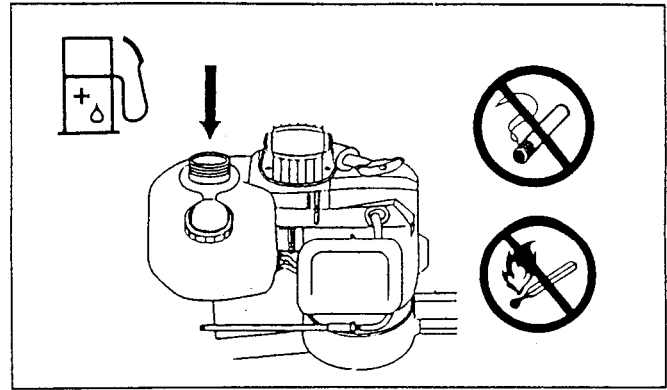
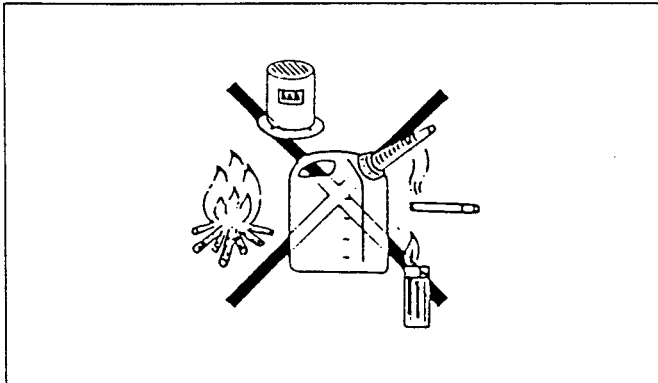

PRECAUTIONS BEFORE STARTING

- Please make sure that there are no children or other people within a working range of 15 meters or 50 feet, also pay attention to any animals in the working vicinity.
 - Before use always check that the Hedge Trimmer is safe for operation. Check the cutting device is not damaged, the control lever for easy action and check for proper function of the STOP switch.
Rotation of the cutting device during idling speed is not allowed. Check with your dealer for adjustment if in doubt. Check for clean and dry handles and test function of the STOP switch.
 - Start the Hedge Trimmer only in accordance with the instructions. Do not use any other methods for starting the engine. (See Starting)
 - Start the hedge Trimmer engine only after the entire assembly is done. Operation of the engine is only permitted after all the appropriate accessories are attached. Otherwise there is a risk of injury.
 - Before starting, make sure that the cutting device has no contact with objects such as branches, stones, etc.
 - Before trimming, inspect area for wires, cords, glass, or other foreign objects which could come in contact with the blade.
- Electrical shock. Be aware of any and all electric lines and electric fences. Check all areas for electrical lines before cutting.

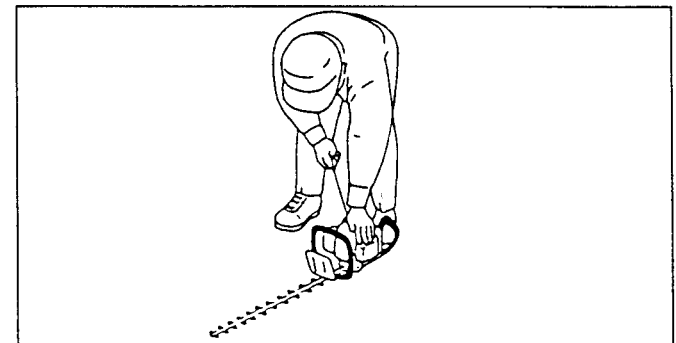
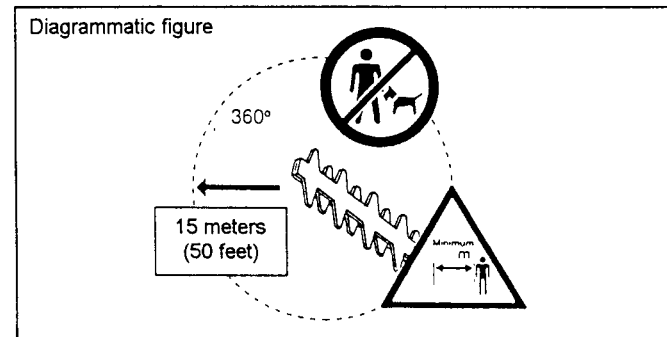

STARTING THE MACHINE

Move at least 3 meters away from the place of refuelling. Place the Hedge Trimmer on a clean area of ground make sure that the cutting tool does not come into contact with the ground or any other objects. Cold starting (When the engine is cold or it has been stopped for more than 5 minutes or when fuel is added to the engine.



1. Push the STOP switch (1) to "1" position.
2. Squeeze first the lock lever A and then the throttle lever B. (fig.1)
3. Keeping the throttle lever B depressed, then press the throttle lock C inward. (fig. 2)
4. Keeping throttle lock C depressed, release the throttle lever B. this will lock the throttle lever B in position. (fig. 3)
5. Give a gentle push on the primer pump (2) repeatedly (7 to 10 times) until fuel comes into the primer pump.
6. Move the choke lever (3) to position (|→|).
7. Hold the unit down firmly so you will not lose control while cranking the engine. If not held down properly, the engine could pull you off balance or swing the cutting blade into an obstruction or your body.
8. Slowly pull the starter grip until resistance is felt and continue with smart pull until initial ignition are heard.
9. Depress the choke lever (3) to the position (|↓|) and pull the starter rope again until the engine starts.
10. As soon as the engine starts, immediately tap and release the throttle, thus releasing the half-throttle rock so that the engine can run in idle.
11. Run the engine for approximately one minute at a moderate speed before applying full speed.

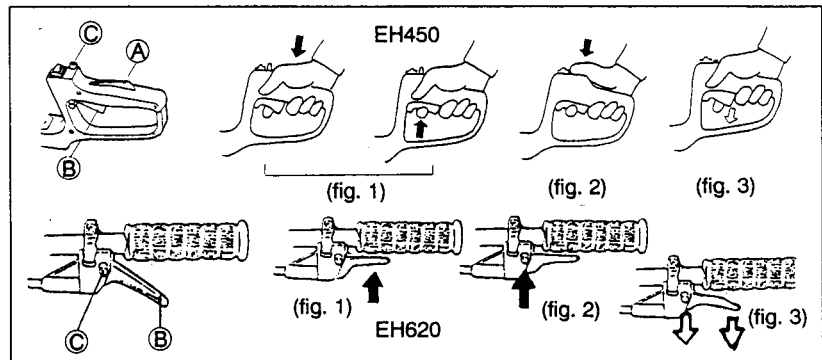
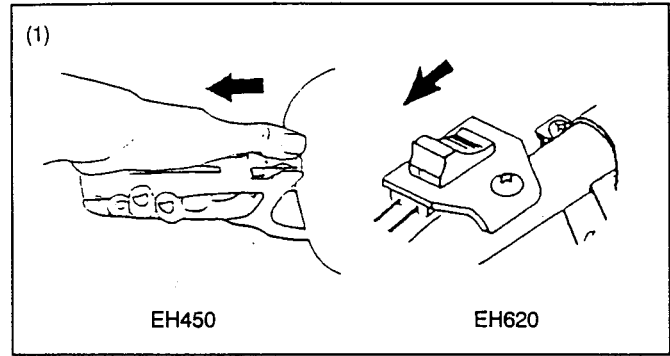

Hot starting: (Restarting immediately after the engine has stopped)
When restarting a hot engine, first try the above procedure: 1, 5, 7, 8. If the engine does not start, repeat above steps 1-11.

Note: Do not pull the starter rope to its full extent and do not allow the starter grip to be retracted without control, ensure that it is retracted slowly.

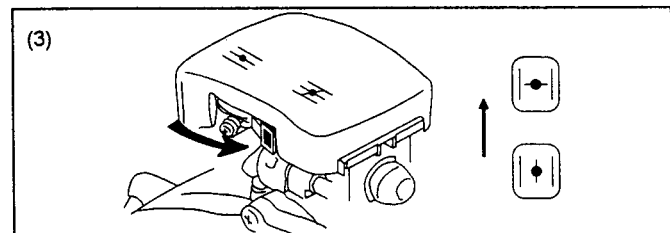
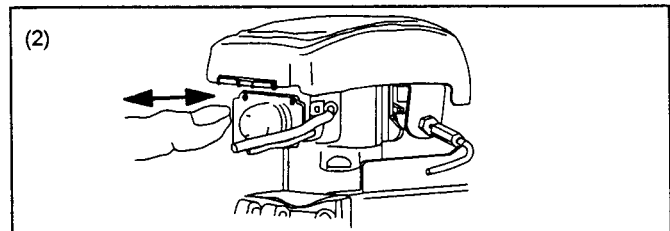
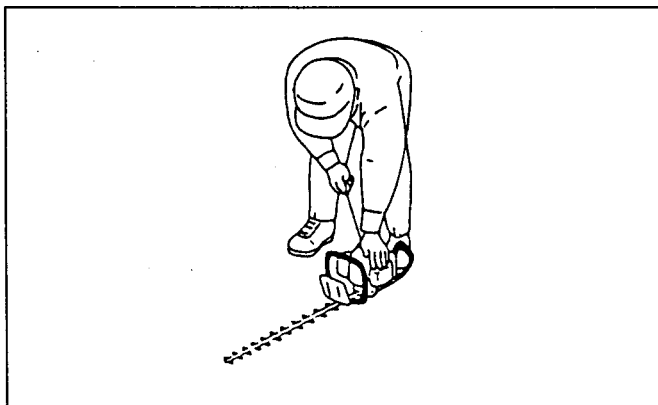

STOPPING THE MACHINE

1. Release the throttle lever completely.
2. Push the I-O switch (on/off switch) to "0" position, the engine rotation will become low and the engine will stop.

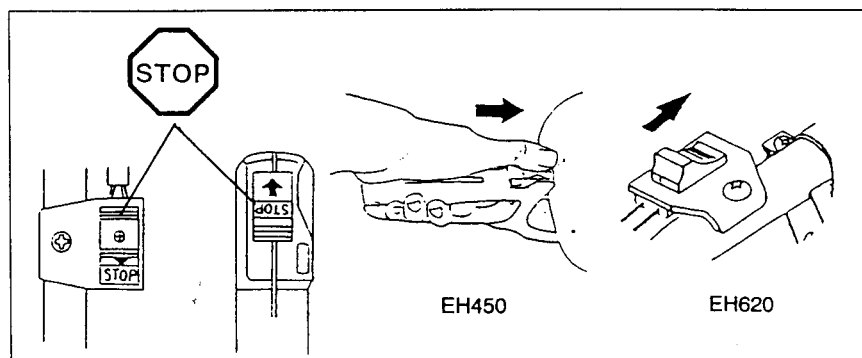

OPERATION OF THE MACHINE

- Be sure to carefully read and follow safety instructions.
- Keep hands away from blades. Never grasp the exposed cutting blade or cutting edges, when picking up or holding the tool.
- Never touch the cutting device when starting the engine and during operation.
- Operate the Hedge Trimmer in such a manner as to avoid inhalation of the exhaust gases. Never run the engine in enclosed rooms (Risk of gas poisoning). Carbon monoxide is an odorless gas.
- All protective installations and guards supplied with the machine must be used during operation.
- Never operate the engine with a faulty exhaust muffler or if it is missing.
- Use the Hedge Trimmer only in good light and visibility. Always ensure a safe footing.
- Never stand on a ladder and run the Hedge Trimmer. Keep both feet on the ground.
- Never climb up the trees with the Hedge Trimmer to perform cutting operation.
- Never work on unstable surfaces.
- Remove sand, stone, nails, wire, etc. found within the working area. Foreign objects may damage the cutting blades.
- Before commencing cutting, the cutting blades must have reached full working speed.
- Always hold the Hedge Trimmer firmly with both hands on the handles only.
- The right hand grips the front handle of model EH620. This is the way to safely operate the machine.
- Use a firm grip with thumbs and fingers encircling the handles.
- When you release the throttle, it takes a few moments before the cutting blades stop.
- The Hedge Trimmer must not be used for cutting with fast idle. The cutting speed cannot be adjusted with the throttle control in fast idle position.
- When cutting a hedge, the machine should be held so that the blades form a 15-30° angle with the cutting line.
- If the Hedge Trimmer is used with circular movements against the edge of the hedge, the twigs will be thrown directly to the ground.
- At vertical cutting, the Hedge Trimmer is used with circular pendulation, swinging up and down close to the hedge.
- Pay special attention when cutting hedges which are laid out a long a wire-fence and have grown through the fence. The blade must not contact the fence, otherwise the blades may be destroyed.
- Do not use the Hedge Trimmer continuously for a long time. It is normal to take a break of 10 to 20 minutes after every 50 minutes operation.
- Should the cutting blades hit stones or other hard objects, immediately switch off the engine and inspect the cutting blades for damage. Replace damaged blades before re-commencing work.
- The engine must be switched off immediately in case of any engine problems.
- Operate the Hedge Trimmer with as little noise and contamination as possible. In particular check the correct setting of the carburetor and the fuel/oil ratio.
- Do Not attempt to remove jammed cut material when blades are running. Put unit down, turn it off, and remove necessary cuttings.

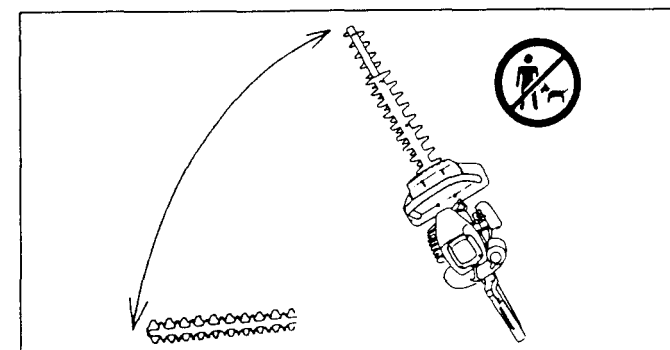
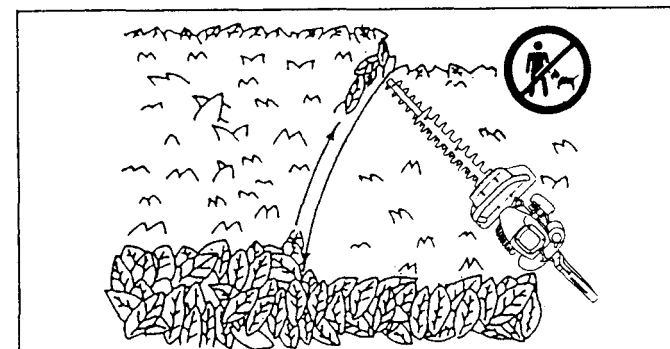
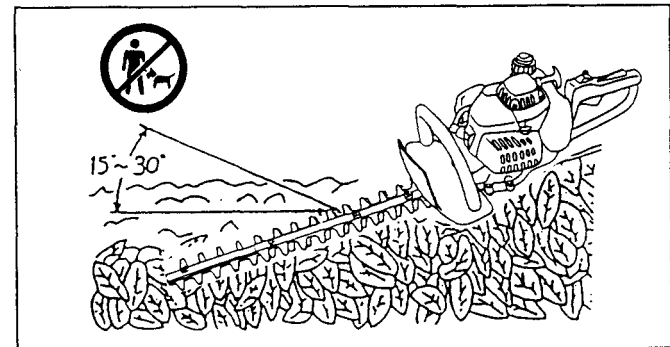
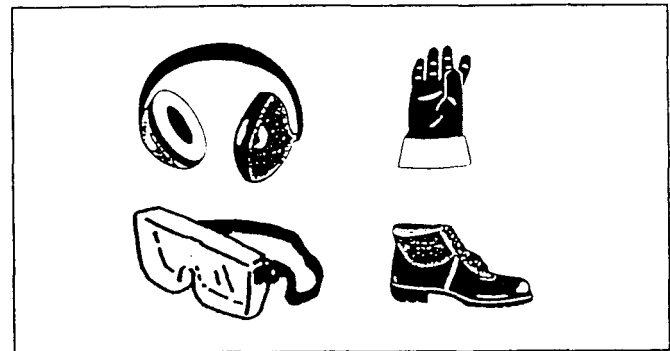
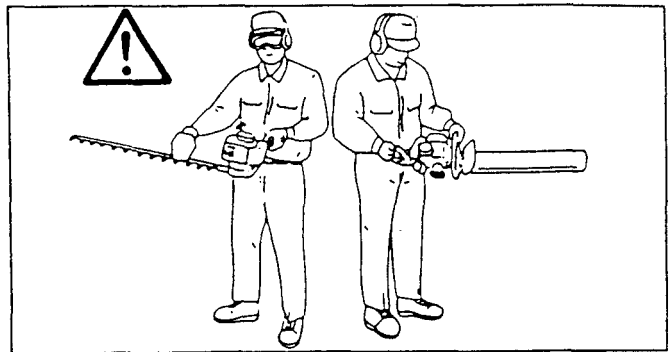

MAINTENANCE INSTRUCTIONS

- Turn off the engine and remove the spark plug connector when replacing or sharpening cutting tools, also when cleaning the cutter or cutting device or carrying out any maintenance.
- Never straighten or weld a damaged cutting blade.
- Inspect the cutting blades with the engine switched off at short, regular intervals for damage. (Detection of hairline cracks by means of tapping-noise test.) Beware the teeth are sharp.
- Clean the Hedge Trimmer at regular intervals and check that all screw and nuts are well tightened.
- Never service or store the Hedge Trimmer in the vicinity of naked flames to avoid fires.
- Always wear leather gloves when handling or sharpening the blades as they are sharp.



Blade sharpening

If the edges are rounded and do not cut well any more, grind off only the shaded portions. Do not grind the contact surfaces (sliding surfaces) of the top and bottom edges.

- Before grinding, be sure to secure the blade firmly and switch off the engine and remove the spark plug cap.
- Wear gloves, protective glasses, etc.
- An edge ground too much at a time or ground many times will lose its hardened layer. It becomes rounded and dull very quickly in use.

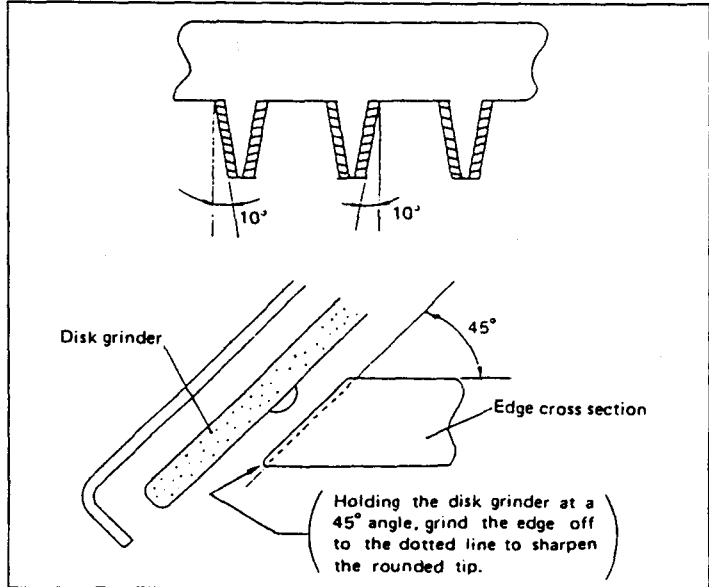

Blade adjustment

The blades will wear with long use. When you find that trimming is not as good as when the blades were new, adjust them as follows:

1. Turn nut ① loose.
2. Screw ② in with the driver lightly till it stops turning, and then screw it back one quarter to a half turn.
3. Turn nut ① tight, holding screw ② at the same time with a driver.
4. Lubricate the blades after adjustments above with light oil.
5. Start the engine and operate the engine throttle on and off for a minute.
6. Stop the engine and touch the blades with your hand. If they are warm enough for you to keep your hand on, then you have made the proper adjustment. If they are too hot for you to keep touching, give screw ② a little more turnback and repeat 5 to see if they are properly adjusted.

NOTE: Never fail to stop the engine before making the adjustment. The blades have a slot around screw ②. In case you find dust in the end of any of the slots, clean it.

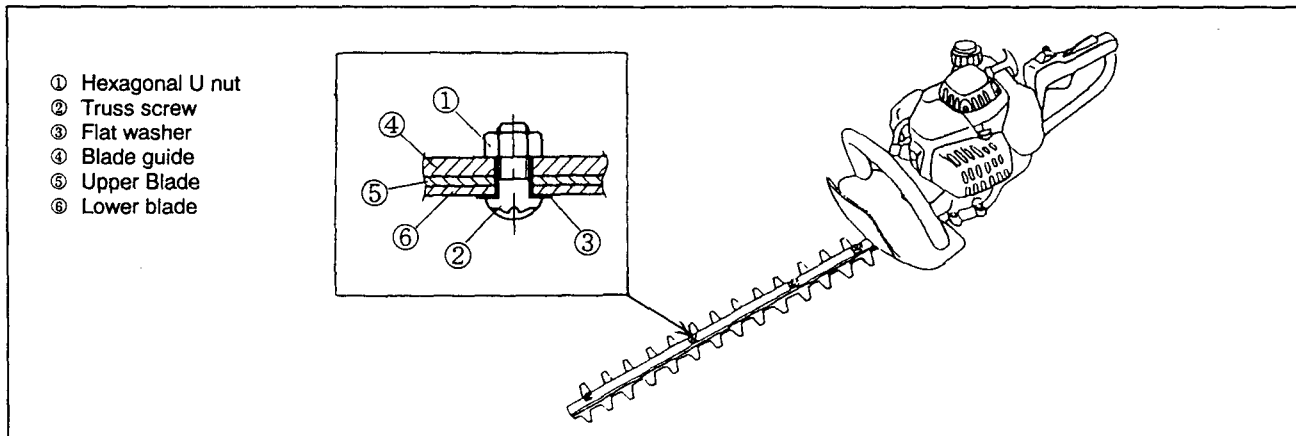

Checking and adjusting the idling speed

The cutting blade should not when the control lever is fully released.

- Idle speed should be set to 2,600 rpm.
If necessary, correct it by means of the idle screw (the cutting blade must not run when the engine is on idle).
- Clockwise : for faster rate of revolution
- Counter-clockwise : for slower rate of revolution Check that there is sufficient difference between idling and clutch engagement speed to ensure that the cutting tool is at a standstill while the engine is idling. (If necessary, reduce idling speed.) If the tool still continues to run under the idling conditions, consult your nearest authorized service agent.
- The clutch should engage at minimum 3,250 rpm.
- Check the functioning of the STOP switch, the lock-off lever, the control lever, and the lock button.

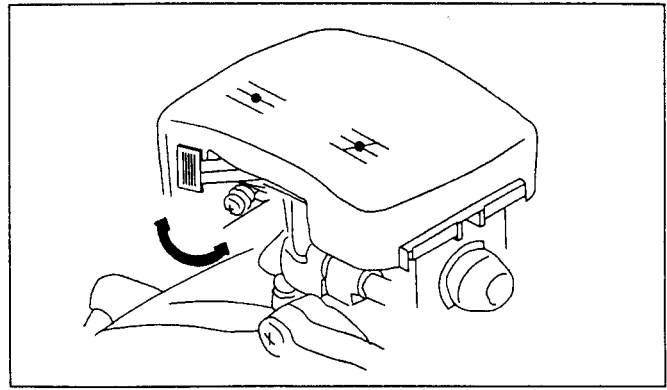

Cleaning of air cleaner - Every 8 hours (Daily)

- Remove the air cleaner cover.
- Push the choke lever up (arrow), to prevent dirt particles from entering the carburetor.
- Take out the sponge element, wash it in lukewarm water and dry it completely.
- After cleaning, put back the sponge element and the air cleaner cover.

NOTE: If there is excessive dust or dirt adhering to the air cleaner, clean it every day. A clogged air cleaner may make it difficult or impossible to start the engine or increase the engine rotation speed which could cause damage.

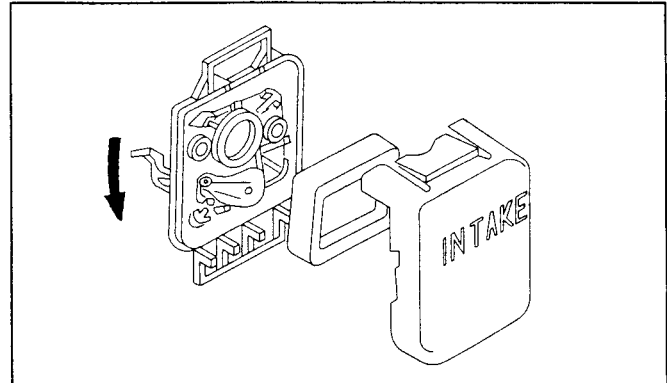

Checking the spark plug - Every 8 hours (Daily)

- Only use the supplied universal wrench to remove or to install the spark plug.
- The gap between the two electrodes of the spark plug should be 0.6 to 0.7mm. If the gap is too wide or too narrow, adjust it. If the spark plug is clogged with carbon or fouled, clean it thoroughly or replace it. Use an exact replacement.

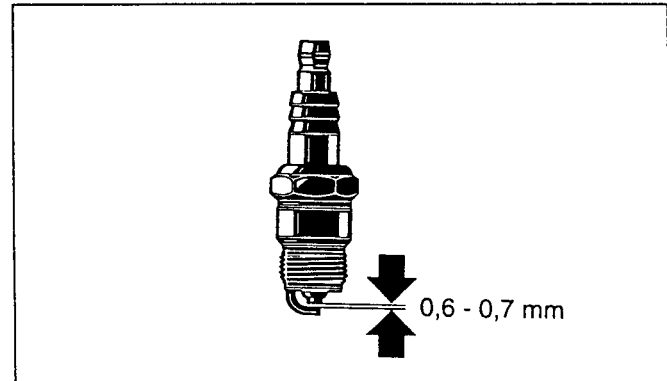

Supply of grease and lubricant

- Supply grease from the grease nipple every 15 operating hours. (Shell Alvania No.3 or equivalent)
The amount of grease for each supply is about 20cc.
(Once grease is supplied regularly as mentioned above, grease will come out from the end of the gear case (root of the cutting edge) in operation just after supply of grease. Confirm this phenomenon as a guide to grease supply.)

NOTE: Be sure to observe the specified time and amount of grease supply.
If the grease supply is not made at the specified interval or if the amount of grease supplied is not sufficient, the machine may fall into a trouble because of lack of grease.

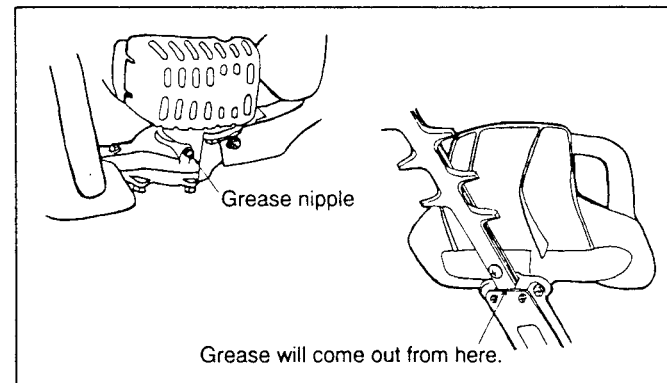

Suction head in the fuel tank - Every 50 hours (Monthly)

- The felt filter (1) of the suction head is used to filter the fuel required by the carburetor.
- A periodical visual inspection of the felt filter is to be conducted. For that purpose, open the tank cap, use a wire hook and pull out the suction head through the tank opening. Filters found to have hardened, been polluted or clogged up are to be replaced.
- Insufficient fuel supply can result in the admissible maximum speed being exceeded. It is therefore important to replace the felt filter at least quarterly to ensure satisfactory fuel supply to the carburetor.

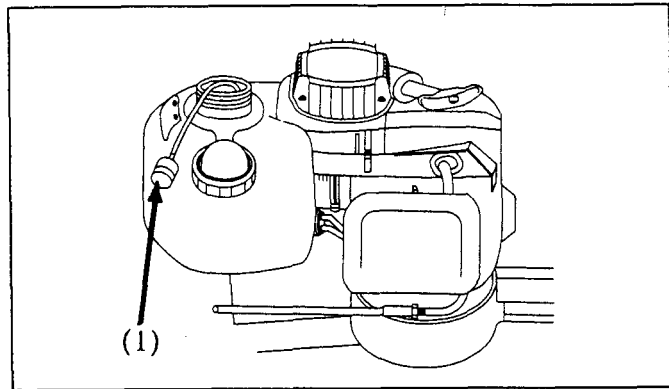

Cleaning of muffler exhaust port - Every 50 hours (Monthly)

- Check of muffler exhaust port (2) regularly.
- If it is clogged by carbon deposits, carefully scratch the deposits out with a suitable tool. Do not allow carbon to fall into engine ports.

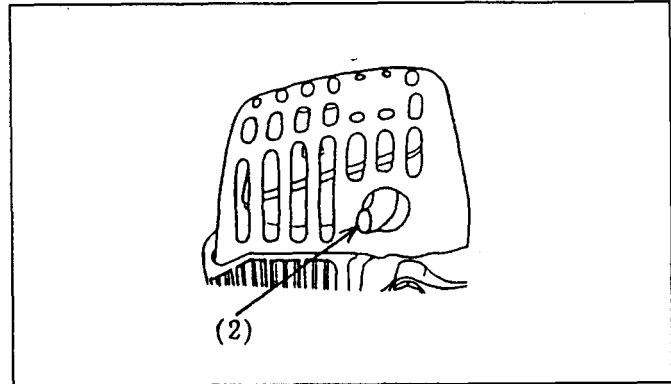

Replace fuel lines: Every 200 hours (yearly)

Overhaul engine: Every 200 hours (yearly)

Replace packings and gaskets with new ones: Every time engine is reassembled.

Any maintenance or adjustment work that has not been included and described in this manual is only to be performed by Authorized Service Agent.

Daily checkup and maintenance

To ensure a long service life and to avoid any damage to the equipment, the following servicing operations should be performed at regular intervals.

- Before operation, check the machine for loose screws or missing parts. Pay particular attention to the tightness of the cutter blade screws. - Every 8 hours (Daily)
- Before operation, always check for clogging of the cooling air passage and the cylinder fins. Clean them if necessary. - Every 8 hours (Daily)
- Perform the following work daily after use:
 - Clean the Hedge Trimmer externally and inspect for damage.
 - Clean the air filter. When working under extremely dusty conditions, clean the filter several times a day.
 - Check the blades for damage and make sure they are firmly mounted.

STORAGE

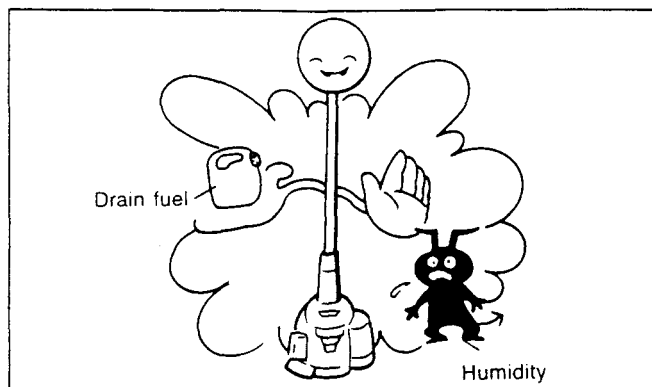

- When keeping the machine in storage for a long time, drain fuel from the fuel tank and carburetor, as follows: Drain all fuel from the fuel tank.
- Remove the spark plug and add a few drops of oil into the spark plug hole. Then, pull the starter gently to confirm that oil film covers the engine inside and tighten the spark plug.
- Clear dirt or dust from the cutter blade and outside of engine, wipe them with a oil-immersed cloth and keep the machine at a place as dry as possible.
- Abide by Federal and Local regulations for safe storage and handling of gasoline.

MAINTENANCE SCHEDULE

General	Engine assembly, screws and nuts	Visual inspection for damage and tightness Check for general condition and security
After each refuelling	Throttle lever Safety lock key STOP switch	Functional check Functional check Functional check
Daily	Air filter Cooling air duct Cutting tool Idling speed	To be cleaned To be cleaned Check for damage and sharpness Inspection (cutting tool must not move)
Every 15 hours	Gear case	Supply of grease
Weekly	Spark plug Muffler	Inspection, replace if necessary Check and if necessary clean the opening
Quarterly	Suction head Fuel tank	To be replaced To be cleaned
Shutting down procedure	Fuel tank Carburetor	Empty fuel tank Operate until engine runs out of fuel

FAULT LOCATION

Fault	System	Observation	Cause
Engine not starting or under difficulties	Ignition system	Ignition spark is present	Faulty fuel supply or compression system, mechanical defect
		No ignition spark	STOP-switch operated, wiring fault or short circuit, spark plug or connector defective, ignition module faulty
	Fuel supply	Fuel tank filled	Incorrect choke position, carburetor defective, suction head (gas line filter) dirty, fuel supply line bent or interrupted
	Compression	Inside of engine	Cylinder bottom gasket defective, crankshaft seals damaged, cylinder or piston rings defective
		Outside of engine	Improper sealing of spark plug
Mechanical fault	Starter not engaging	Ignition spark existing	Broken starter spring, broken parts inside of the engine
			Carburetor contaminated, have it cleaned
Warm start problems	Fuel supply	Tank filled	Incorrect idling adjustment, suction head or carburetor contaminated
			Fuel tank vent defective, fuel supply line interrupted, cable or STOP-switch faulty
Insufficient performance	Several systems may simultaneously be affected	Engine idling	Air filter contaminated, carburetor contaminated, muffler clogged, exhaust duct in the cylinder clogged

California Emission Control Warranty Statement

[This warranty does not apply in any other state.]

YOUR WARRANTY RIGHTS AND OBLIGATIONS

The California Air Resources Board and Makita U.S.A., Inc. are pleased to explain the emission control warranty on your 1995 and later utility and/or lawn and garden equipment engine. In California, new utility and lawn and garden equipment engine must be designed, built and equipped to meet the State's stringent anti-smog standards. Makita U.S.A., Inc. must warrant the emission control system on your utility and/or lawn and garden equipment engine for the periods of time listed below provided there has been no abuse, neglect or improper maintenance of your utility and/or lawn and garden equipment engine.

Your emission control system includes parts such as the carburetor or fuel injection systems, the ignition system and the catalytic converter. Also included are the hoses and connectors and other emission-related assemblies.

Where a warrantable condition exists, Makita U.S.A., Inc. will repair your utility and/or lawn and garden equipment at no cost to you including diagnosis, parts and labor.

MANUFACTURER'S WARRANTY COVERAGE:

The 1995 and later utility and/or lawn and garden equipment engines are warranted for two years. If any emission-related part on your engine is defective, the part will be repaired or replaced by Makita U.S.A., Inc.

OWNER'S WARRANTY RESPONSIBILITIES:

As the utility and lawn and garden equipment engine owner, you are responsible for the performance of the required maintenance listed in your owner's manual. Makita U.S.A., Inc. recommends that you retain all receipts covering maintenance on your utility and/or lawn and garden equipment engine, but Makita U.S.A., Inc. cannot deny warranty solely for the lack of receipts or for your failure to ensure the performance of all scheduled maintenance.

As the utility and/or lawn and garden equipment engine owner, you should be aware, however, that Makita U.S.A., Inc. may deny you warranty coverage if your utility and/or lawn and garden equipment engine or a part has failed due to abuse, neglect, improper maintenance or unapproved modifications.

You are responsible for presenting your utility and/or lawn and garden equipment engine to a Makita U.S.A., Inc. service center as a problem exists. The warranty repairs should be completed in a reasonable time, not to exceed 30 days.

If you have any questions regarding your warranty rights and responsibilities, you should contact a Makita Factory Service Center Manager nearest you. A list of the Factory Service Center locations and phone numbers is provided on page 20 for your convenience.

LIMITED WARRANTY

- California Only -

Makita U.S.A., Inc. a distributor of utility and lawn and garden equipment in the U.S., warrants to the owner of 1995 and later utility and/or lawn and garden equipment engines that the engine (1) has been designed, built, and equipped at the time of manufacture so as to conform with the applicable regulations of the California Air Resources Board, and (2) is free from defects in materials and workmanship which may cause it to fail to conform with those regulations as applicable according to the terms and conditions stated below.

WARRANTY PERIOD

The warranty period begins on the date which the utility and/or lawn and garden equipment engine is delivered to the original retail purchaser and ends two years after that date. During this two year period Makita U.S.A., Inc. warrants to the original retail purchaser and each subsequent purchaser that the engine is free from defect in material and workmanship that can cause the failure of a warranted emission-related part.

WHAT IS COVERED UNDER THIS WARRANTY

Repair and/or replacement of any warranted emission-related part will be performed at no charge provided the work is performed at an authorized warranty station. There will also be no charge for any diagnostic labor performed at an authorized warranty station which leads to the determination that a warranted emission-related part is defective.

Any warranted part which is not scheduled for replacement as required maintenance, or which is scheduled only for regular inspection to the effect of "repair or replace as necessary" shall be warranted for the warranty period. Any warranted part which is scheduled for replacement as required maintenance shall be warranted for the period of time up to the first scheduled replacement of the part. This warranty shall apply only towards the repair, replacement, and/or adjustment of the component parts listed below.

EMISSION-RELATED PARTS COVERED UNDER THIS WARRANTY

1. Fuel Metering Systems
 - (a) Carburetor and its internal parts
 - (b) Air cleaner plate
 - (c) Air cleaner case
 - (d) Air cleaner element
 - (e) Fuel filter
2. Ignition Systems
 - (a) Spark Plug
 - (b) Flywheel Magneto
 - (c) Ignition Coil
3. Other Miscellaneous Items Used in Above Systems
 - (a) Fuel Hoses
 - (b) Sealing Gaskets

If it is determined by an authorized warranty station that other engine components have been damaged due to the failure of a warranted emission-related part during the warranty period, Makita U.S.A., Inc. will repair and/or replace the necessary components.

WHAT IS NOT COVERED UNDER THIS WARRANTY

This warranty does not cover any emission-related part which malfunctions, fails, or is damaged due to alterations and/or modifications such as changing, adding, or removing parts.

When an engine is being serviced under warranty, Makita U.S.A., Inc. and any of its authorized dealers, distributors, or warranty stations shall not be liable for any loss of use of the engine, for any damage to goods, or loss of time or inconvenience.

This limited warranty also does not apply to any emission-related part which malfunctions, fails, or is damaged due to failure to follow the maintenance and operating instructions specified in the 1995 and later Owner's Manual including:

- (a) Improper or inadequate maintenance of any warranted emission-related part.
- (b) Improper installation, adjustment, or repair of the engine or any warranted emission-related part unless performed by a factory authorized warranty station.
- (c) Failure to use recommended fuel as specified in the 1995 and later Owner's Manual.
- (d) Repairs and diagnosis performed outside of an authorized warranty station.
- (e) Use of parts which are not authorized by Makita U.S.A., Inc.

MAINTENANCE SCHEDULE

The engine owner is responsible for having all scheduled inspection and maintenance services performed at the intervals specified in the 1995 and later Owner's Manual and to retain records of these services as having been performed. These records should be transferred to each subsequent owner of the engine. Makita U.S.A., Inc., cannot deny a claim solely because there are no records of scheduled maintenance; however, a warranty claim may be denied if the failure to perform the scheduled maintenance and inspection resulted in the failure of a warranted emission-related part. As a minimum, the engine owner is responsible for the scheduled inspection and maintenance described below which are based on the procedures described in the Owner's Manual.

PROCEDURE

INTERVAL

- | | |
|--|---------------------------------------|
| (a) Check all nuts and bolts and tighten as necessary | Every 8 hours of use or daily. |
| (b) Check air passages and engine cylinder fins for clogging.
Remove all obstructions as necessary. | Every 8 hours of use or daily. |
| (c) Clean air cleaner. | Every 8 hours of use or daily. |
| (d) Check the spark plug. Clean and adjust it if necessary. | Every 8 hours of use or daily. |
| (e) Check the muffler exhaust port. Clean it if necessary. | Every 50 hours of use or monthly. |
| (f) Check the fuel filter. If clogged, replace it with new filter. | Every 50 hours of use or monthly. |
| (g) Replace fuel lines. | Every 200 hours of use or annually. |
| (h) Overhaul the engine. | Every 200 hours of use or annually. |
| (i) Replace the packings and gaskets. | Every time the engine is reassembled. |

REPAIR AND REPLACEMENT OF EMISSION-RELATED PARTS

It is recommended that only engine replacement parts which have been authorized and approved by Makita U.S.A., Inc. should be used in the performance of any warranty maintenance or repairs of emission-related parts. These replacement parts will be provided at no charge if the part is still under warranty.

HOW TO FILE A WARRANTY CLAIM AND WHERE TO GET WARRANTY SERVICES

Contact the nearest Makita Factory Service Center Manager to determine the appropriate location where the required warranty services are to be performed. A list of the Factory Service Center locations and phone numbers are provided below for your convenience.

14930 Northam Street
La Mirada, CA 90638-5753
(714) 522-8088

41850 Christy Street
Fremont, CA 94538-5107
(510) 657-9881

1421N. Clovis Ave., Ste. 112
Fresno, CA 93727
(209) 252-5166

7674 Clairemont Mesa Blvd.
San Diego, CA 92111
(619) 278-4471

1440 South "E" Street
San Bernardino, CA 92408
(909) 885-1289

1714 E McFadden Ave., Unit M
Santa Ana, CA 92705
(714) 667-5066

16735 Saticoy St., Ste. 105
Van Nuys, CA 91406
(818) 782-2440

1565 Winchester Blvd.
Campbell, CA 95008-0501
(408) 379-0377

1970 Fulton Avenue
Sacramento, CA 95825
(916) 482-5197

FEDERAL EMISSION COMPONENT DEFECT WARRANTY

EMISSION COMPONENT DEFECT WARRANTY COVERAGE - This emission warranty is applicable in all States, except the State of California

Makita U.S.A., Inc., La Mirada, California, (herein "MAKITA") warrant to the initial retail purchaser and each subsequent owner, that this utility equipment engine (herein "engine") was designed, built, and equipped to conform at the time of initial sale to all applicable regulations of the U.S. Environmental Protection Agency (EPA), and that the engine is free of defects in materials and workmanship which would cause this engine to fail to conform with EPA regulations during its warranty period.

For the components listed under PARTS COVERED, Makita Factory Service Center or service center authorized by MAKITA will, at no cost to you, make the necessary diagnosis, repair, or replacement necessary to ensure that the engine complies with applicable U.S. EPA regulations.

EMISSION COMPONENT DEFECT WARRANTY PERIOD

The warranty period for this engine begins on the date of sale to the initial purchaser and continues for a period of 2 years.

PARTS COVERED

Listed below are the parts covered by the Emission Component Defect Warranty. Some of the parts listed below may require scheduled maintenance and are warranted up to the first scheduled replacement point for that part.

- 1) Fuel Metering System
 - (i) Carburetor and internal parts
 - (ii) Fuel filter, if applicable
 - (iii) Throttle stopper, if applicable
 - (iv) Choke System, if applicable
- 2) Air Induction System
 - (i) Air cleaner plate
 - (ii) Air cleaner case
 - (iii) Air cleaner element
- 3) Ignition System
 - (i) Spark plug
 - (ii) Flywheel Magneto
 - (iii) Ignition Coil
- 4) Miscellaneous Items Used in Above Systems
 - (i) Fuel hoses, clamps and sealing gaskets

OBTAINING WARRANTY SERVICE

To obtain warranty service, take your engine to the nearest Makita Factory Service Center or Service Center authorized by MAKITA. Bring your sales receipts indicating date of purchase for this engine. The dealer or service center authorized by MAKITA will perform the necessary repairs or adjustments within a reasonable amount of time and furnish you with a copy of the repair order. All parts and accessories replaced under this warranty become the property of MAKITA.

WHAT IS NOT COVERED

- * Conditions resulting from tampering, misuse, improper adjustment (unless they were made by the dealer or service center authorized by MAKITA during a warranty repair), alteration, accident, failure to use the recommended fuel and oil, or not performing required maintenance services.
- * The replacement parts used for required maintenance services.
- * Consequential damages such as loss of time, inconvenience, loss of use of the engine of equipment, etc.
- * Diagnosis and inspection charges that do not result in warranty-eligible service being performed.
- * Any non-authorized replacement part, or malfunction of authorized parts due to use of non-authorized parts.

OWNER'S WARRANTY RESPONSIBILITIES

As the engine owner, you are responsible for the performance of the required maintenance listed in your owner's manual, MAKITA recommends that you retain all receipts covering maintenance on your engine, but MAKITA can not deny warranty solely for the lack of receipts or for your failure to ensure the performance of all scheduled maintenance.

As the engine owner, you should however be aware that the MAKITA may deny your warranty coverage if your engine or a part has failed due to abuse, neglect, improper maintenance or unapproved modifications.

You are responsible for presenting your engine to the nearest Makita Factory Service Center or service center authorized by MAKITA when a problem exists.

If you have any questions regarding your warranty rights and responsibilities, you should contact the Makita Warranty Service Department at 1-800-4-MAKITA for the information.

THINGS YOU SHOULD KNOW ABOUT THE EMISSION CONTROL SYSTEM WARRANTY

MAINTENANCE AND REPAIRS

You are responsible for the proper use and maintenance of the engine. You should keep all receipts and maintenance records covering the performance of regular maintenance in the event questions arise. These receipts and maintenance records should be transferred to each subsequent owner of the engine. MAKITA reserves the rights to deny warranty coverage if the engine has not been properly maintained. Warranty claims will not be denied, however, solely because of the lack of required maintenance or failure to keep maintenance records.

MAINTENANCE, REPLACEMENT OR REPAIR OF EMISSION CONTROL DEVICES AND SYSTEMS MAY BE PERFORMED BY ANY REPAIR ESTABLISHMENT OR INDIVIDUAL; HOWEVER, WARRANTY REPAIRS MUST BE PERFORMED BY MAKITA FACTORY SERVICE CENTER OR SERVICE CENTER AUTHORIZED BY MAKITA. THE USE OF PARTS THAT ARE NOT EQUIVALENT IN PERFORMANCE AND DURABILITY TO AUTHORIZED PARTS MAY IMPAIR THE EFFECTIVENESS OF THE EMISSION CONTROL SYSTEM AND MAY HAVE A BEARING ON THE OUTCOME OF WARRANTY CLAIM.

If other than the parts authorized by MAKITA are used for maintenance replacements or for the repair of components affecting emission control, you should assure yourself that such parts are warranted by their manufacturer to be equivalent to the parts authorized by MAKITA in their performance and durability.

HOW TO MAKE A CLAIM

All repairs qualifying under this limited warranty must be performed by Makita Factory Service Center or service center authorized by MAKITA. In the event that any emission-related part is found to be defective during the warranty period, you shall notify Makita Warranty Service Department at 1-800-4-MAKITA and you will be given the appropriate warranty service facilities where the warranty repair can be performed.

MEMO

A large rectangular area with rounded corners, filled with horizontal dotted lines for writing. The lines are evenly spaced and extend across the width of the page, providing a guide for text entry. The entire page is enclosed in a thin black border.



WARNING: The Engine Exhaust from this product contains chemicals known to the state of California to cause cancer, birth defects or other reproductive harm.

Makita Corporation

3-11-8, Sumiyoshi-cho,
Anjo, Aichi 446-8502, Japan